

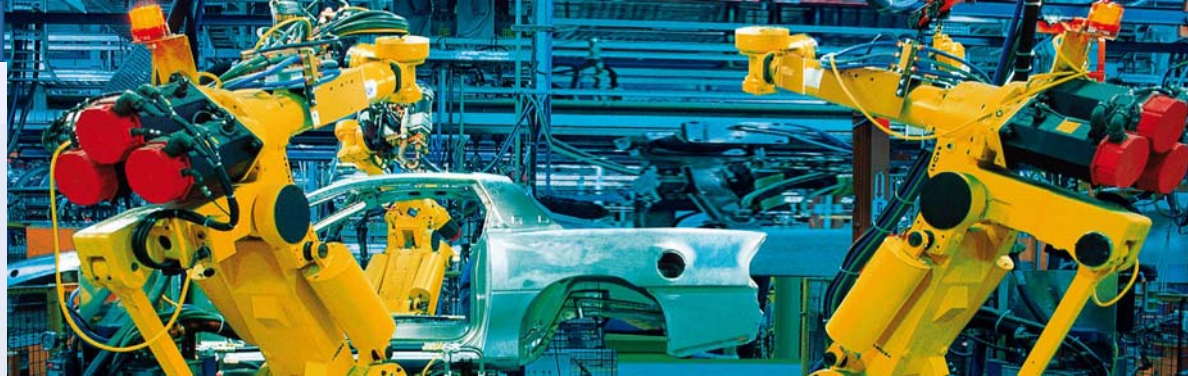

Technical Report

PQS



Different Connections of PF Controllers BR6000-series

P o w e r Q u a l i t y S o l u t i o n s

www.epcos.com/pfc

Power Factor Correction

Different connections of PF controllers BR6000-series V3.0 to V5.0

In the last years our well proven PF controller series BR6000 was step by step upgraded and has reached version V5.0 meanwhile. With each new version the previous version becomes obsolete. In terms of performance and characteristics, the change only means an enhancement or improvement as a benefit for the user.

Nevertheless, it is important to point out that there are major differences in voltages and phase programming of the different versions (i.e. BR6000 V3.0, V4.0 and V5.0). These differences have to be considered when replacing an old or defective device with the existing version.

BR6000-Version 3.0 (discontinued)

Measuring voltage input 30 - 300 V

In the menu "Programming", the parameter 8 "Measuring Voltage" refers to the voltage "on the measuring input" (L-N grid voltage).

Default connection: Current: L1, Voltage: L1-N

If connected differently, set in the "Expert Mode", parameter 12 "PHASE U/I" the respective phase-shift angle.

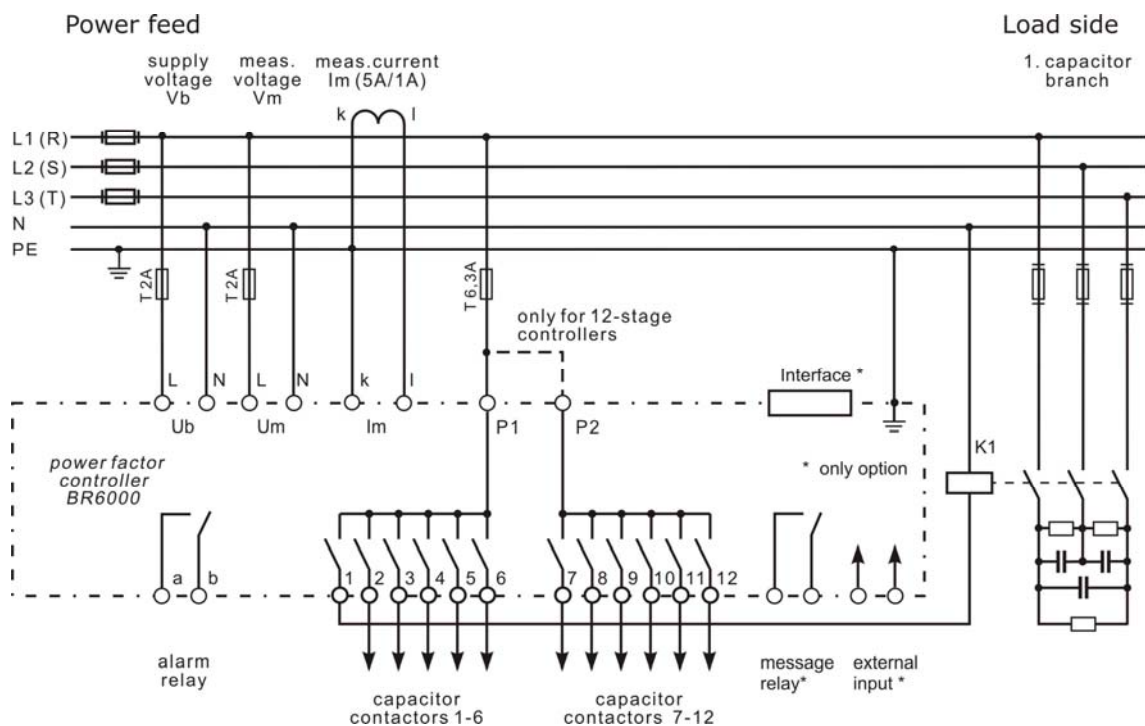

BR6000-Version 4.0 (discontinued)

Measuring voltage input 30 – 300 V

In the menu “Programming” the parameter 8 “Measuring Voltage” refers to the voltage “on the measuring input” (L-N grid voltage).

Default connection: Current: L1, Voltage: L1-N

If connected differently set in the “Expert Mode 1”:

- the parameter 12 “PHASE I” to the phase from which the current is taken,
- the parameter 13 “PHASE V” to the phase from which the voltage is taken.

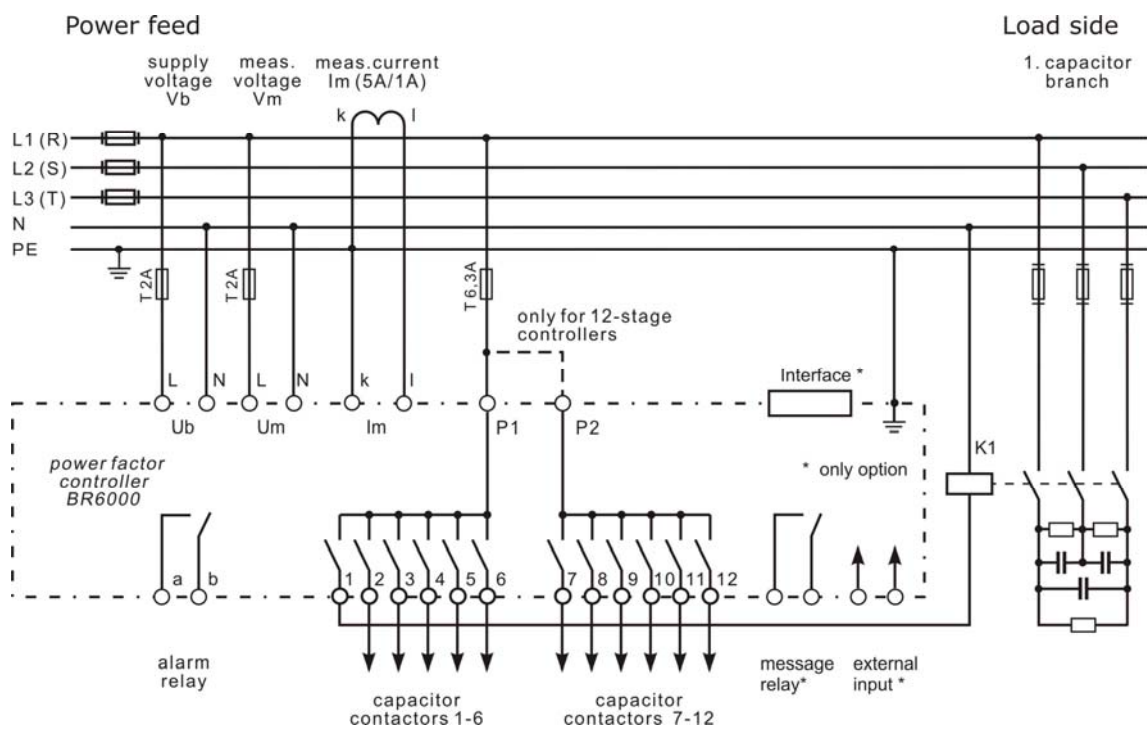

BR6000-Version 5.0

Measuring voltage input 30 – 525 V

In the menu “Programming” the parameter 8 “Measuring Voltage” refers to the voltage “on the measuring inputs” This can be L-N or L-L (see example 1 and 2).

Default connection: Current: L1, Voltage: L1-N – example 1

If connected differently set in the “Expert Mode 1”:

- the parameter 12 “PHASE I” to the phase from which the current is taken,
- the parameter 13 “PHASE V” to the phase from which the voltage is taken.

Example 1

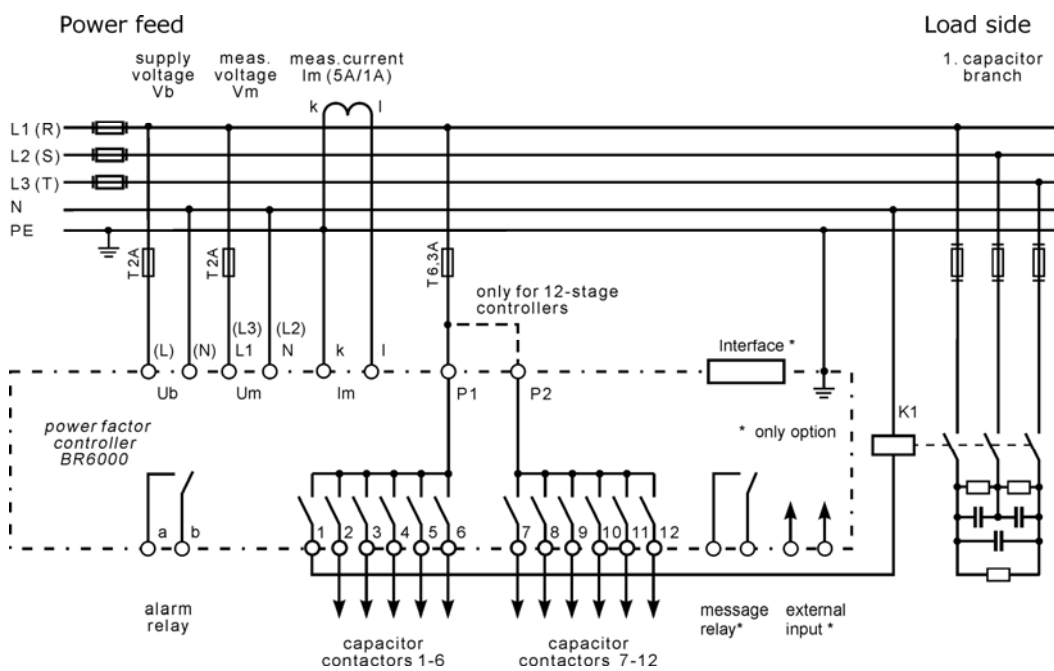

Example 2

(Current in L1, voltage from L2-L3)

ExpertMode1: set "12 Phase I" to L1, set "13 Phase V" to L2-L3

Programming: set "8 Measuring voltage" to 400 V

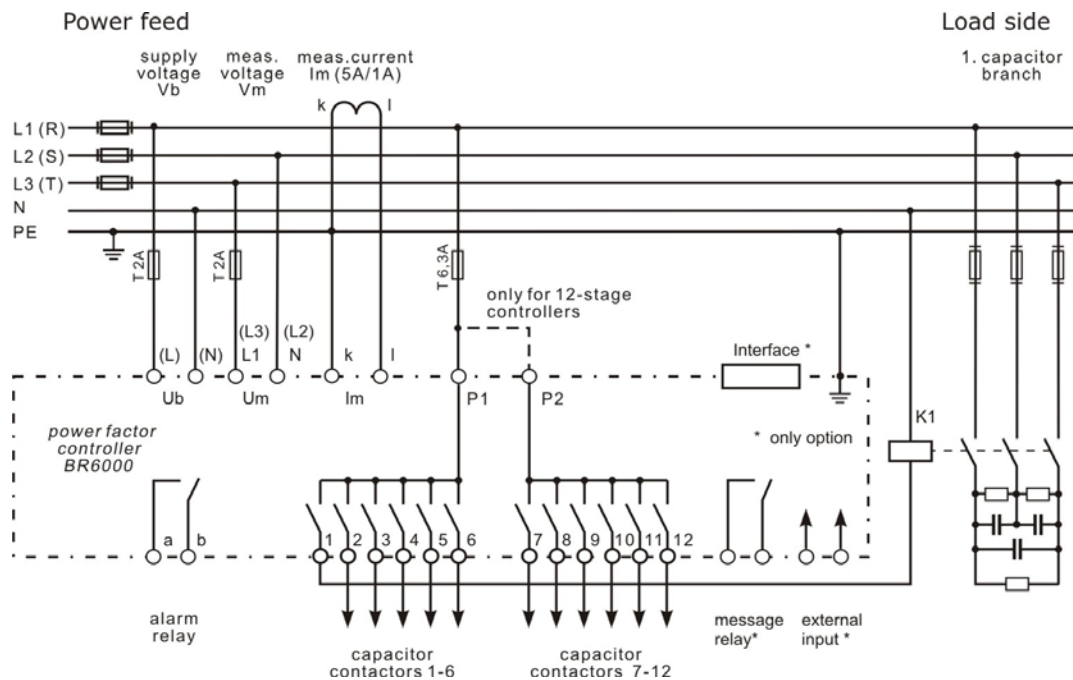

Note: Due to the fact that the version V5.0 can deal with higher measuring voltage, no neutral adapter is required. The BR6000 from version V5.0 onwards is designed for direct usage in grids without neutral up to 525 V.

The adapter B44066R9999E230 has been withdrawn as obsolete product.

Important Notes

Some parts of this publication contain statements about the suitability of our products for certain areas of application. These statements are based on our knowledge of typical requirements that are often placed on our products for a particular customer application. It is incumbent on the customer to check and decide whether a product is suitable for use in a particular application. This technical report may be changed from time to time without prior notice. Our products are described in detail in our data sheets. The Important Notes (www.epcos.com/ImportantNotes) and the product specific warnings and cautions must be observed. All relevant information is available through our sales offices.