



## **EMC filters**

### Mounting instructions

Date: January 2006

## EMC filters

### Mounting instructions

EMC cannot be assured by the use of EMC filters alone. Every system should be considered as an integrated whole and careful planning and preparation are required to ensure success. Measures such as shielded motor cables, grounding and spatial separation are mandatory parts of an integrated concept.

#### Plan your EMC!

- Identify interference sources (with interference emissions) and disturbed equipment (electrical equipment or components with limited interference immunity).
- Assign interference sources and disturbed equipment to specific zones and separate them spatially from each other.
- Plan the cabling in wiring categories in accordance with interference emissions and interference immunity.

**EMC is an indispensable quality feature!** The legally stipulated protection objectives and technical risks must be taken into consideration as early as the development stage of the system.

In order to achieve electromagnetic compatibility of the overall system the following points must be observed:

1. The **filter case should be connected across a large area to ground and to the other equipment.**

For example, a blank metal mounting plate should be provided jointly for filters and converters. It should be well grounded and connected to the switch cabinet via a large-area low-inductance connection. If necessary, use short copper tapes and EMC seals (e.g. connection to switch cabinet doors).

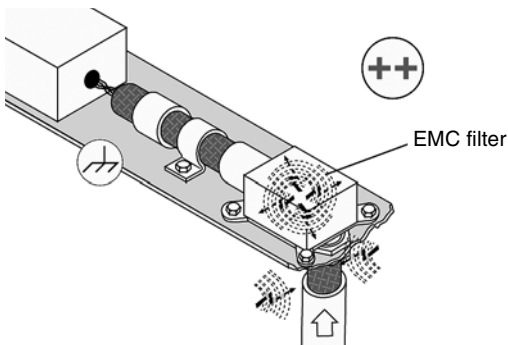

The figures in the Chapter "Mounting instructions" were made available by Rittal-Werk, Herborn and Euratherm Regler GmbH, Limburg/Lahn.

## EMC filters

### Mounting instructions

2. A distinction should be made between

- the protective earth connection of the EMC filter (see also requirements on the PE connection in the Chapter “General”, section 8.4, page 68), which is used to secure protection against hazardous body currents, and
- the large-area grounding of the filter, which is required for its interference suppression function.

 For operating currents greater than 250 A, we recommend the PE connection to be set up between the feed (filter: line) and output (filter: load) not via the PE terminal bolt in the filter housing. This is because of the restricted area of the cable lug of the PE connection to the filter housing. Ideally, the PE feed line should be connected with the PE output line to a PE busbar which also carries the PE terminal(s) of the EMC filter. The number of necessary PE connections to the filter depends on the cross-section and the required KU factor as a function of the magnitude of the leakage current (see also Section 8.4 "Safety notes on leakage current"). The PE conductor connections must satisfy the requirements defined in IEC 60364-5-54 (DIN VDE 0100 T540). For currents >1000 A and/or short-circuit currents >25 kA, it is not permissible to loop the PE conductor through the filter housing.

3. In your system, set up **connections at the same reference potential** in order to reduce galvanically coupled interferences. All metallic reference potentials of housings, machines and installations should be linked via a low-impedance connection suited for RF and intermeshed as far as possible.

Set up large-area metallic connections, use equipotential busbars and set up short connections to ground via flat ribbon cables.

## EMC filters

### Mounting instructions

The following conditions apply:

- large-area ground connection,
- low-inductance connection  
(preferably a copper ribbon and not circular conductors),
- short connections (rule of thumb: length divided by width < 3).

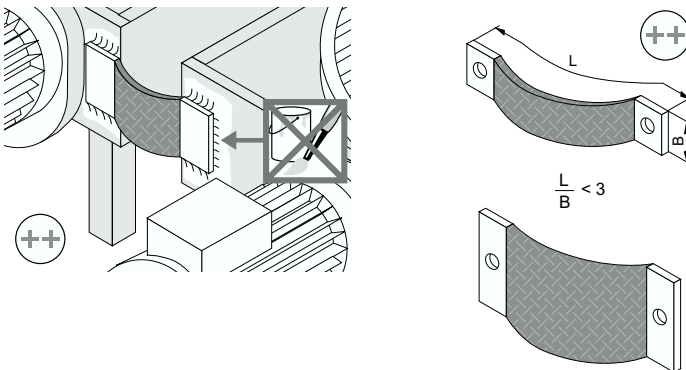
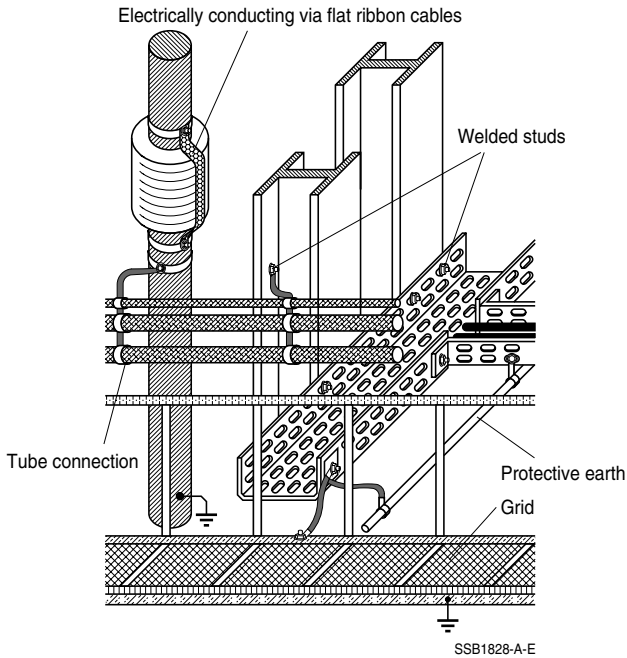

## EMC filters

### Mounting instructions

#### 4. Keep cables from the interference source as short as possible!

Examples:

- short connection from the converter to the EMC filter; ideally a flange mounted filter to avoid emissions.
- connection cables of minimum length between converter output and motor (also to reduce asymmetrical currents caused by the parasitic capacitances of the cable shield).

#### 5. Interference-carrying cables must be shielded!

Examples:

- Connection cables between frequency converter and motor, if no corresponding output filter is used.
- Connection cables filter and converter on the line side, where not directly flange mounted
- It should be noted that the shielding effect of different cables can differ widely (foil shield, braided shield with various degree of coverage, combinations).

#### 6. Connect shielded cables on both sides and across a large-area with reference potential, as far as possible directly or close to the input or output sides of the housing.

Use

- EMC-compliant cable fittings (360° contact)
- an EMC baseplate
- large-area contacting of the cable shield by suitable metal clips.

#### Avoid shielded terminals connected via top lines (pig tails)!

(Twisted shield braiding; soldered cable lugs etc.)

Best

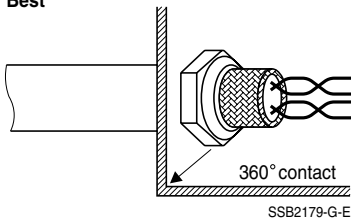

No

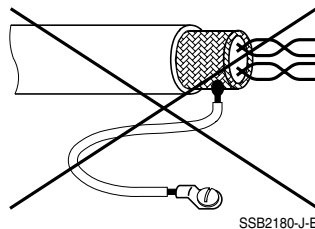

Correct

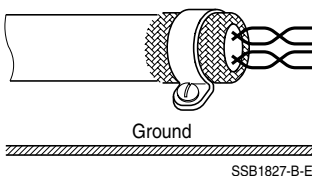

## EMC filters

### Mounting instructions

Ensure that an EMC-compliant cable gland is provided at the motor terminal box. It must correspond to the degree of protection for its respective location of use. The motor terminal box shall be made of metall, the connection between cable gland and terminal box must be of large-area design. If the lacquer has been removed, it may be necessary to restore the corrosion-protection layer.

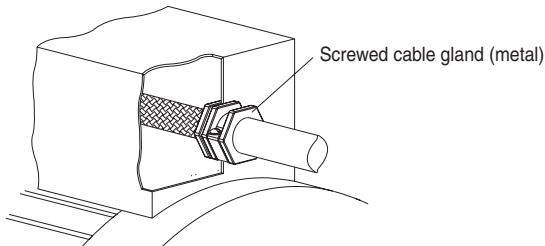

SSB1673-S-E

#### 7. Arrange EMC filters as far as possible directly at the entry or exit points of the housing

Examples:

- Line terminals are accessible via the corresponding opening of the equipment (ensure protection against electric shock).
- Use of suitable EMC filters.
- Use of corresponding housing matching elements to ensure the required shielding attenuation (see Chapter “Application notes, example – marine applications”, page 111).

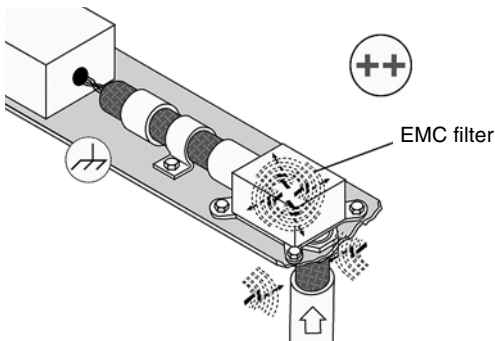

## EMC filters

### Mounting instructions

8. **Spatial separation** between interference-emitting and “clean” cables must be ensured (noisy cables include those between converter and filter, whereas “clean” cables include those between mains supply and filter).

Avoid running cables in parallel (to reduce coupled interferences).

Note the spatially separated laying of signal and power cables in order to avoid coupling routes (minimum recommended spacing 20 cm). Use separating metal plates and ground them across a wide area if necessary.

As far as possible, run cable cross-overs at right angles and keep them well separated.

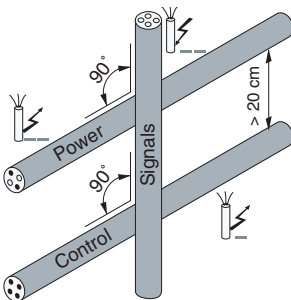
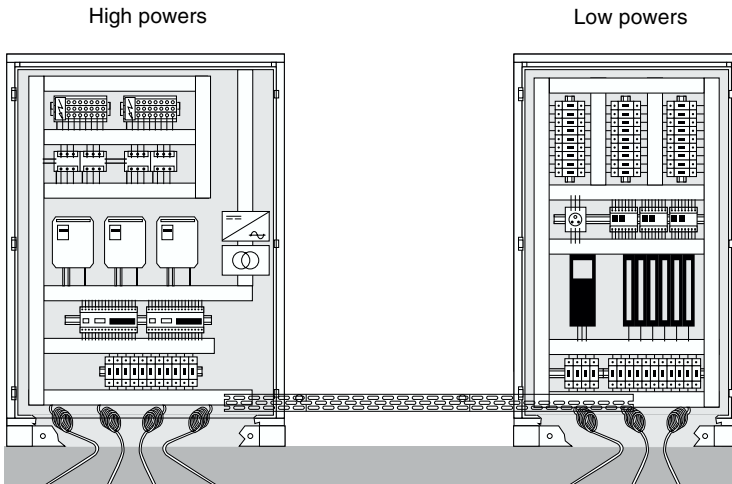

## EMC filters

### Mounting instructions

9. In order to reduce interference coupling, as far as possible run the cables close to **metal parts which are connected** to the reference potential (mounting plates, switch cabinet etc.)

Live cables should also be run as close as possible to the reference potential (to reduce inductively coupled interferences).

In order to improve electromagnetic compatibility, cable channels, cable trays and installation tubes which are made of metal rather than plastic parts should be preferred.

Open metallic cable channels

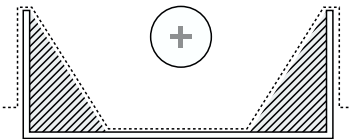

 Regions with a good shielding effect against electromagnetic fields

10. In the case of unshielded signal cables (forward and return lines) use twisted-pair cables in order to minimize the area between the wires (to avoid magnetic coupling). The same applies to avoiding loops.
11. Connect suitable EMC components close to switched inductors (e.g. contactors, relays, magnetic valves etc.).
12. For control signals in the vicinity of high interference levels, use transmission techniques such as:
- Differential-mode transmission systems with twisted-pair lines in conjunction with data line chokes (see also our data book “Chokes and Inductors”).
  - Transmission of digital signals according to the RS-422 standard or in extreme cases crossing the interference region with fiber-optic cables.
13.  Note the mounting position of the filters! The assembly must always take care not to impair natural convection. This includes the use of ventilation slits in the filter housing and sufficient spacing to the other components. Over-head mounting is never permissible. In the event of unusual mounting situations, the thermal conditions shall be checked after coordination with EPCOS.
14. Noise minimization
- A choke made of highly diverse core materials represents a significant frequency-dependent filter component. Electro-acoustic effects must inevitably be expected in AC applications. The materials and processing used generate (for industrial sector) suitable noise levels by operation in networks with harmonics complying to EN 50160. However, these can rise significantly in the event of higher harmonic components. For sensitive applications such as office installation, therefore, customers should contact EPCOS for advice.

## EMC filters

### Mounting instructions

#### 15. Length of motor cables and motor types used

For converter applications, output voltages are generated that typically have almost rectangular waveforms. These are essentially characterized by the rise rate expressed as the  $dv/dt$  value and the switching frequency of the converter. The cables and motors present in the output network of the converter with their inductive and capacitive components significantly determine the EMC properties of the system. Thus resonances of the cable/motor combination are often reflected in the resonance of the interference voltage measurement at the converter input.

**⚠** The parasitic capacitances of the cable and motor should be treated with special care. Whereas the parasitic capacitances of the motor depend on its design, those of the cables depend on the insulation material, cable structure, type of shielding and especially on their length. A high-frequency current flows through the grounded parts of the equipment as a function of the switching frequency, the  $dv/dt$  value and the magnitude of the parasitic capacitances.

**⚠** Here are some of the possible effects:

- As the parasitic currents flow via the ground connection of the installation, the sum of the input currents into the filter is no longer equal to zero. A specific magnitude of the parasitic current can lead to a saturation of the common-mode choke in the EMC filter and consequently exceed the permissible interference level. The interference voltage should therefore be measured on the installed equipment.
- The parasitic currents also flow to the interference source via the filter housing and the capacitors connected in the filter! Impermissibly high currents can overload the capacitors and thus endanger the equipment!

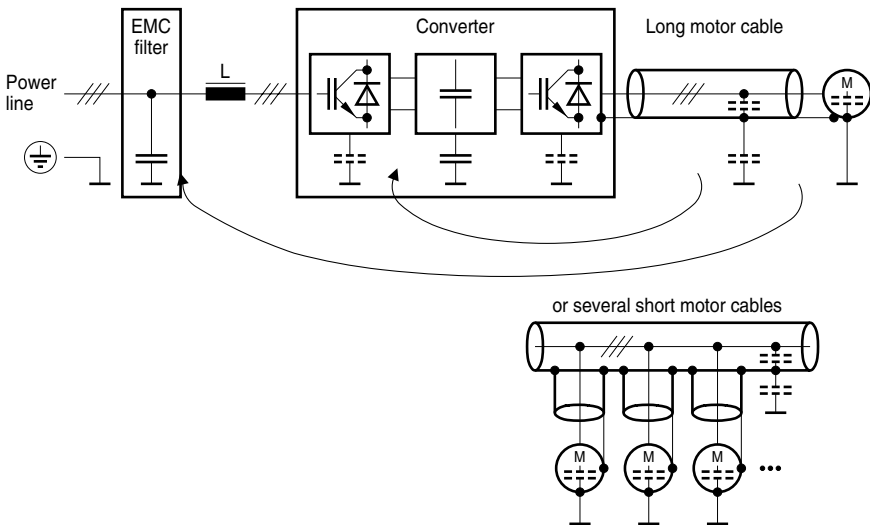

SSB2177-Z-E